

LPMS
USA

Low Pressure Molding
Solutions from Design
to Production



BETA 300

Table-top, compact, horizontal-injection, system with integrated melt-tank

- ◆ Horizontal-injection system with a single-injection gun
- ◆ Compact design with integrated melt-tank
- ◆ 7.5" touchscreen PLC with multi-language capabilities
- ◆ Two thermal zones for precise melt control
- ◆ Equipped with programmable ejection system
- ◆ Equipped with a safety-light curtain and side doors for operator safety

Dimensions

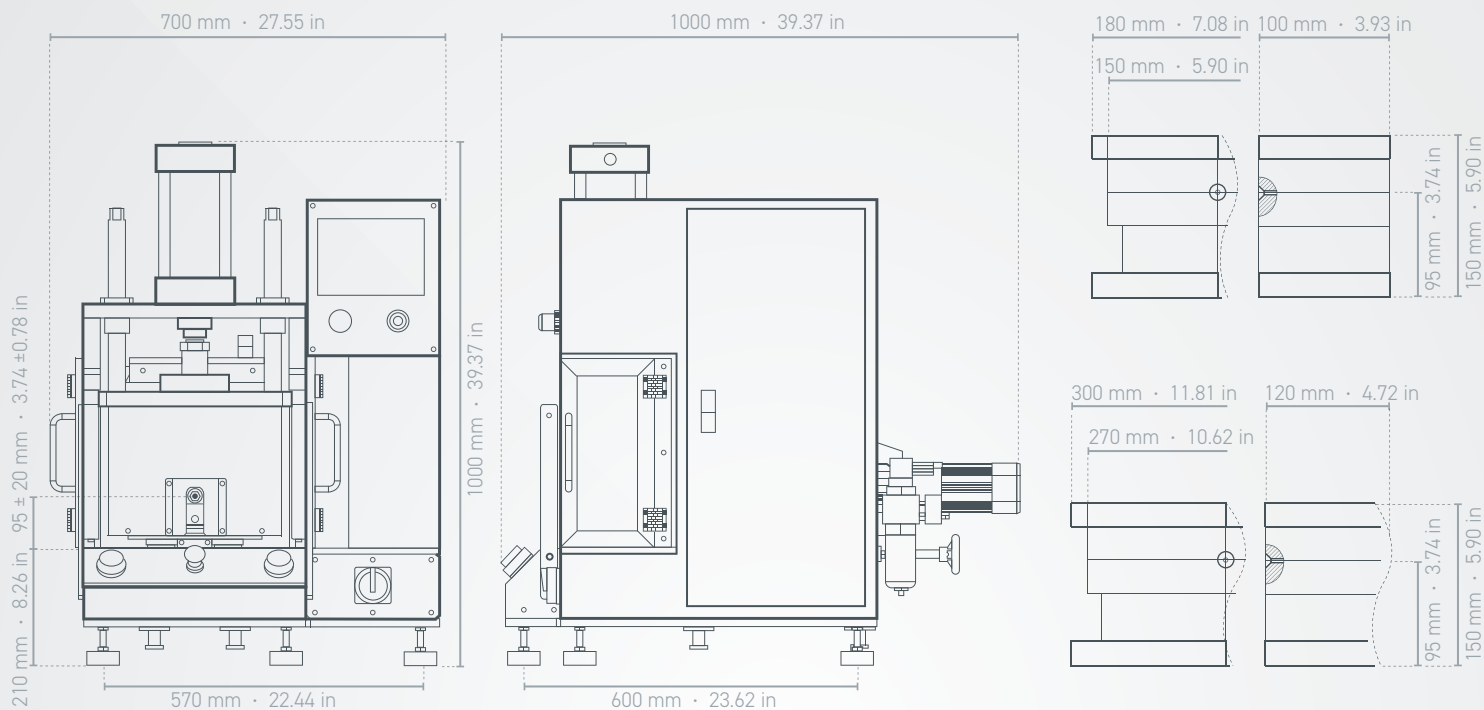

Machine

Mold Set

Specifications

Machine Size	700 × 950 × 1020 mm · 27.36 × 37.40 × 40.16 in · 595 lbs
Electricity	200-240 VAC · 1 Phase · 60 Hz · 25 A
Air Input	30-100 psi
Air Required	> 90 psi
Clamping Method	Pneumatic
Clamping Force	1.2 Tons
Clamping Stroke	125 mm (or optional 150 mm)
Max. Mold Size	Standard: 295 × 170 × 125 mm · Upgraded Cylinder: 295 × 170 × 150 mm
Platen Size	245 × 170 mm
Nozzle	LPMS-G02
Safety Features	Light curtain · E-stop button · Safety doors
Melt Tank Quantity / Volume	One integrated · 3L or 7L
Temperature Control Zones	2